

TRL 100 - Industry

High pressure blower

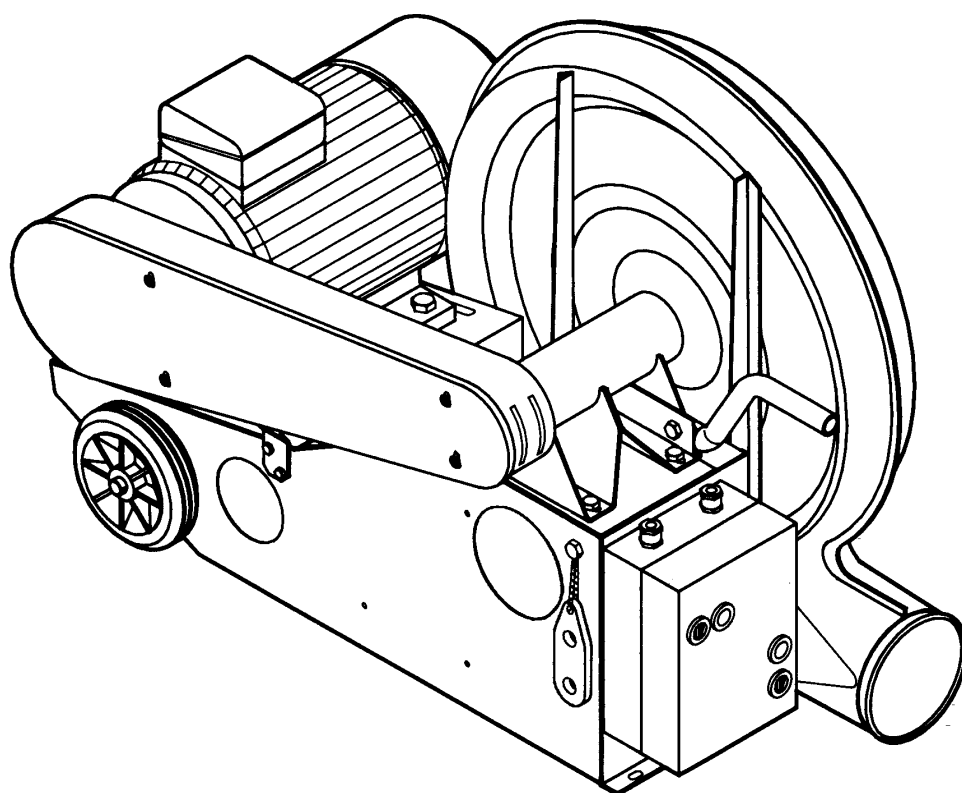

Spare parts list

TRL 100 Industry

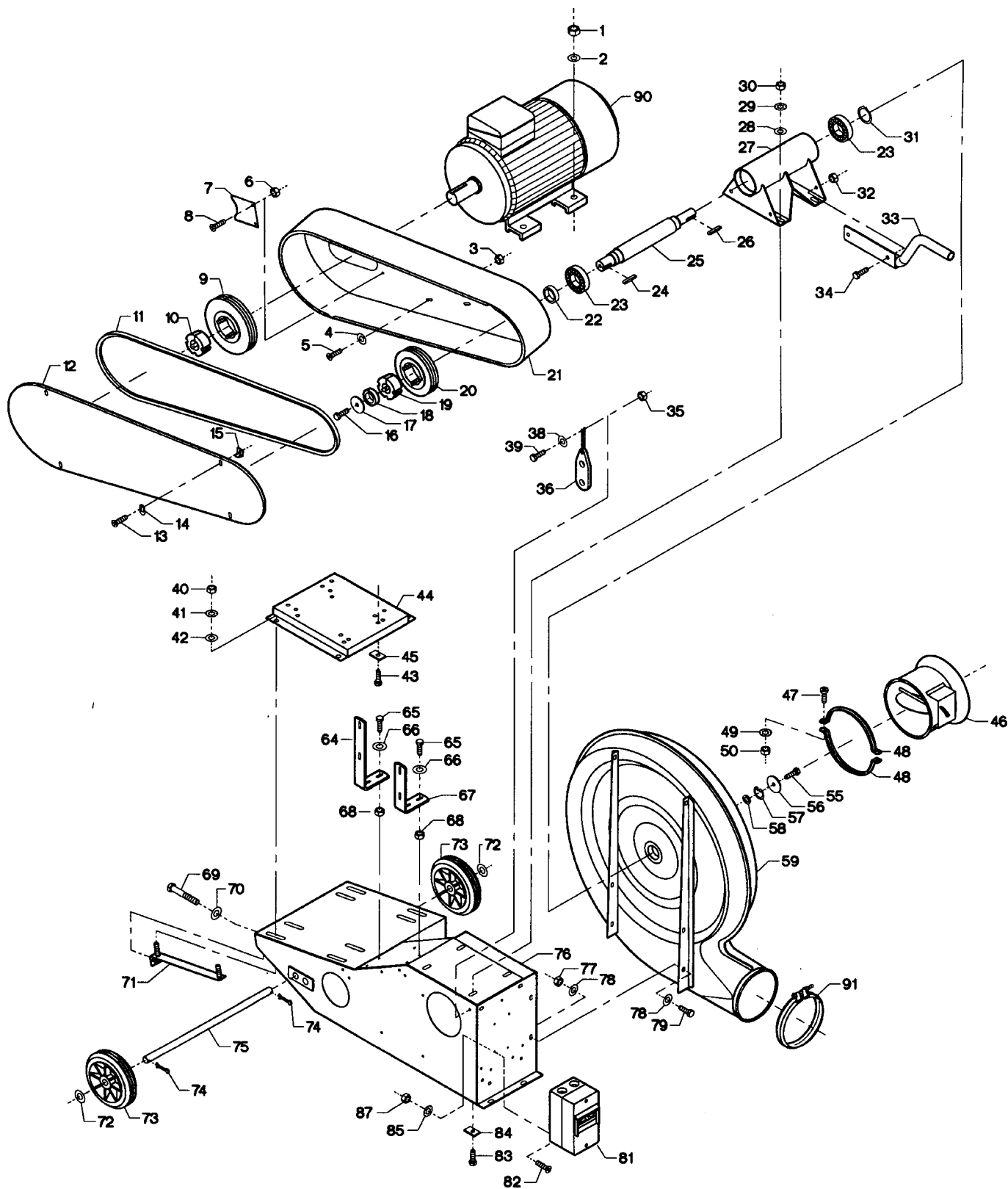

Fig.	Part no.	Pieces	Notes
1	100 315 013	4	Nut M10
2	100 332 004	4	Star washer M10
3	100 316 075	4	Flanged nut M6
4	100 331 004	4	Flat washer M6
5	100 321 015	4	Torx screw M6 x 16 mm
6	100 316 002	2	Lock nut M6
7	121 075 062	1	
8	100 321 013	2	Torx screw M6 x 10 mm
9	121 075 061	1	V-belt pulley SPZ 165 with 3 grooves, TB-2012
10	123 000 468	1	TB-2012-38
11	100 403 241	3	Raw edge moulded notch V-belt SPZ 1787
12	121 123 232	1	
13	100 321 010	4	Torx screw M5 x 12 mm
14	121 000 686	4	
15	121 000 402	4	
16	100 306 029	1	Screw M10 x 25 mm
17	121 000 060	1	Flat washer ø53/11 x 3 mm
18	123 000 378	1	Spacer
19	123 000 183	1	TB-2012-32
20	121 081 164	1	V-belt pulley SPZ 132 with 3 grooves, TB-2012
21	121 081 170	1	
22	113 026 064	1	
23	100 401 072	2	Ball bearing # 6208 - 2RS1/C3 GJN
24	100 405 014	1	Key 10 x 8 x 28 mm
25	113 026 063	1	
26	100 405 015	1	Key 8 x 7 x 36 mm
27	113 026 067	1	
Cpl:	121 090 044	1	Incl. fig 22 - 27 + 31
28	100 331 006	4	Flat washer M10
29	100 332 004	4	Star washer M10
30	100 315 013	4	Nut M10
31	100 407 012	1	Circlip ø40 x 1.5 mm
32	100 316 004	2	Lock nut M10
33	121 081 150	1	
34	100 308 004	2	Screw M10 x 20 mm
35	100 316 002	1	Lock nut M6
36	100 511 028	1	For 50 Hz
	100 511 000	1	
38	100 331 004	1	Flat washer M6
39	100 306 001	1	Screw M6 x 20 mm
40	100 315 016	4	Nut M12
41	100 332 005	4	Star washer M12
42	100 331 016	4	Flat washer M12
43	100 308 037	4	Screw M10 x 40 mm
44	121 066 029	1	
45	121 000 058	4	Washer 25 x 40 x 5 mm/ø11 mm
46	121 080 164	1	
47	100 321 018	2	Torx screw M6 x 30 mm
48	121 000 727	2	
49	100 332 002	2	Star washer M6
50	100 315 028	2	Nut M6
55	100 306 029	1	Screw M10 x 25 mm
56	121 000 060	1	Flat washer ø53/11 x 3 mm
57	100 407 001	1	Circlip ø28 x 1.2 mm
58	121 000 027	1	Flat washer ø27.8/17 x 2 mm
59	121 081 154	1	
64	121 081 180	1	
65	100 316 001	4	Screw M6 x 20 mm
66	100 331 004	4	Flat washer M6
67	121 081 179	1	
68	100 316 002	4	Lock nut M6
69	100 308 017	2	Set screw M12 x 130 mm
70	100 331 007	2	Flat washer M12
71	121 080 133	2	
72	100 331 009	2	Flat washer M20
73	100 412 001	2	Wheel MA-EN 508 50/20 - 180/45
74	100 333 004	2	Split pin ø5 x 30 mm
75	121 081 134	1	
76	121 081 142	1	
77	100 316 003	4	Lock nut M8
78	100 331 005	8	Flat washer M8
79	100 306 014	4	Screw M8 x 16 mm
81	100 503 004	1	For 3 x 400 V - 50 Hz
82	100 321 005	2	Torx screw M4 x 16 mm
83	100 308 004	4	Screw M10 x 20 mm
84	121 000 058	4	Washer 25 x 40 x 5 mm/ø11 mm
85	100 332 000	2	Star washer M4
87	100 315 004	2	Nut M4
90	100 501 060	1	Motor - 132 SX2 - 7.5 kW - 3 x 400 V - 50 Hz
91	122 000 857	1	Bolt clamp OK160

Kongskilde Industries A/S

Tel. +45 33 68 35 00

mail@kongskilde-industries.com

www.kongskilde-industries.com