

## ***SUC 500 T/TR***

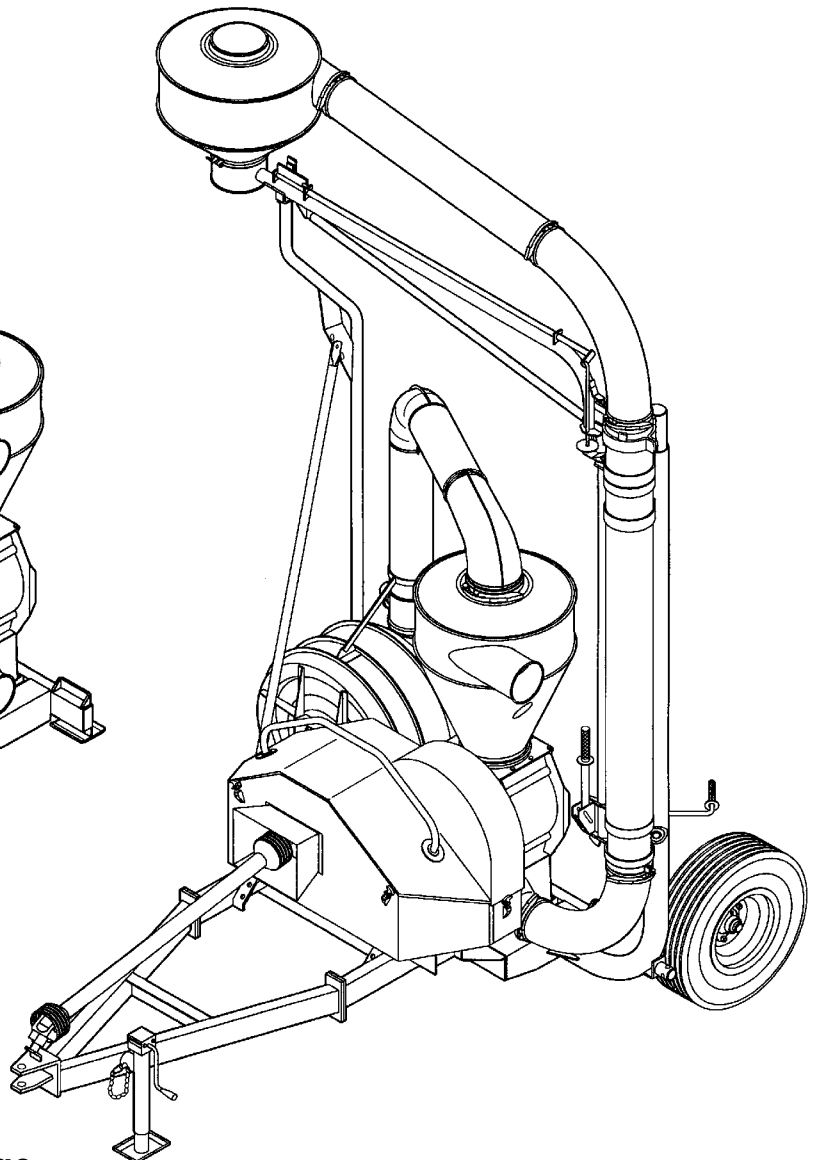

**Reservedelsliste  
Spare parts list  
Ersatzteilliste  
Onderdelenlijst  
Liste de pièce de rechange  
Lista dei pezzi di ricambio**

# SUC 500 T2/TR2

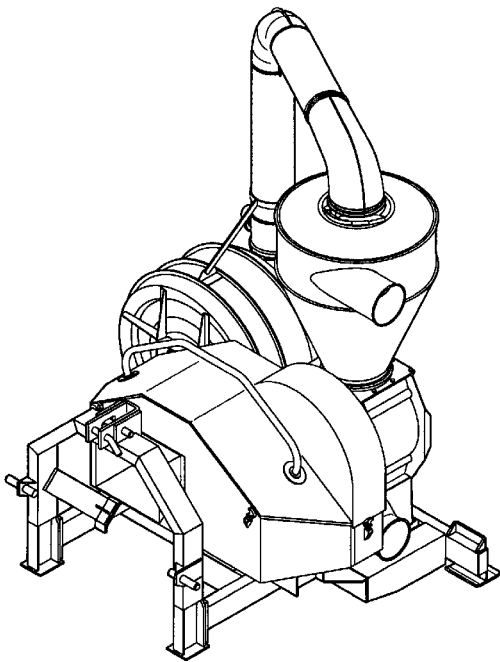
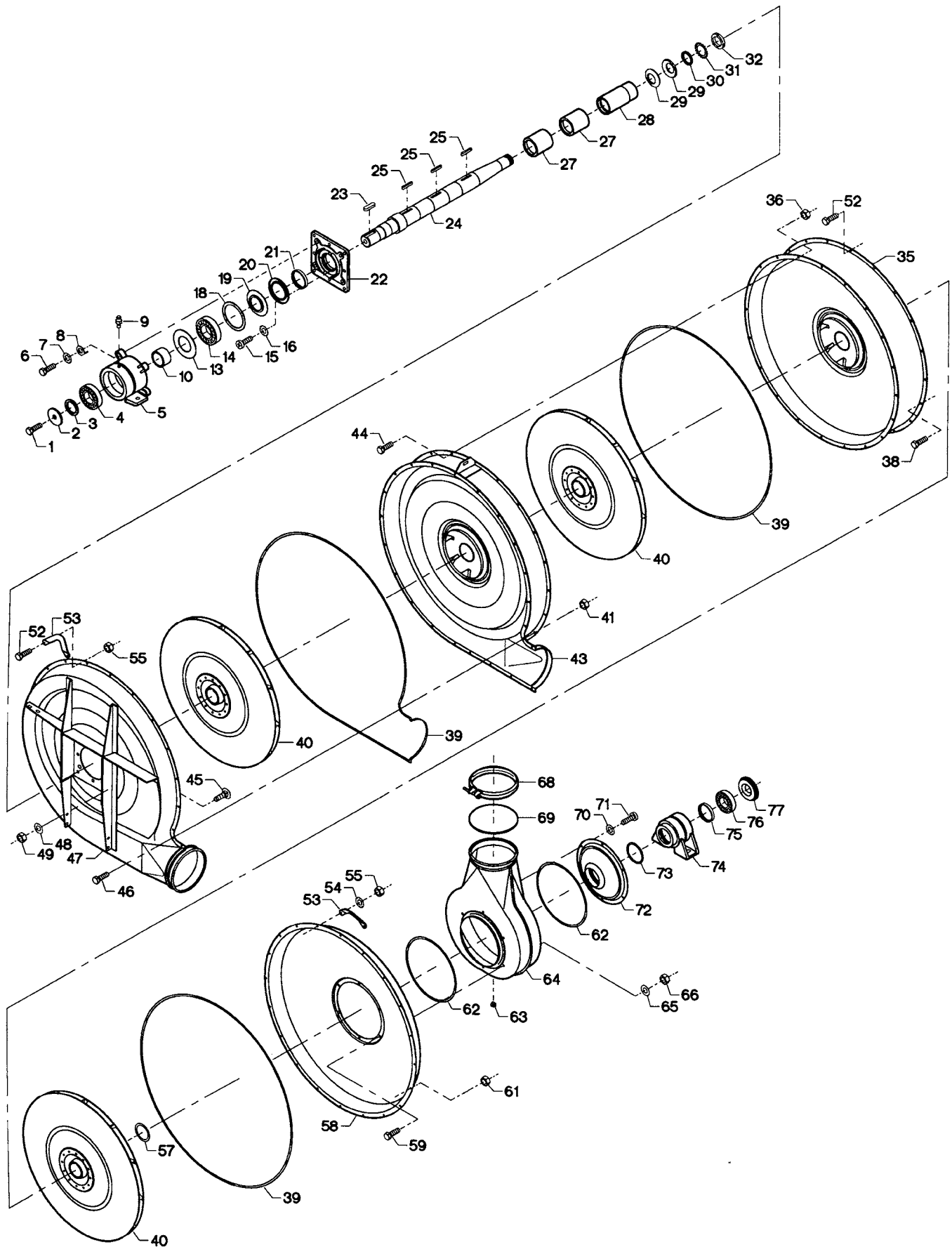

Fig.	Part no.	Pieces	Notes
1	100 304 044	1	Set screw M16 x 30 mm
2	121 121 079	1	
3	121 130 228	1	
4	100 401 043	1	Ball bearing # 6309 Z C3
5	121 130 264	1	
6	100 304 033	4	Set screw M12 x 35 mm
7	100 332 005	4	Star washer M12
8	121 140 024	4	
9	100 421 000	1	Grease nipple M6
10	121 130 241	1	
13	100 323 344	1	99 x 109 x 0.6 mm
14	100 401 042	1	Ball bearing # 6310 Z C3
15	100 321 010	4	Torx screw M5 x 12 mm
16	100 332 001	4	Star washer M5
18	100 323 343	1	Spacer ZW 90 x 110 mm
19	121 140 019	1	
20	121 140 017	1	
21	121 150 243	1	
22	121 140 176	1	
23	100 405 005	1	Key 14 x 9 x 40 mm
24	121 130 223	1	Complete incl. items 1 - 24
Cpl.	121 130 251	1	
25	100 405 013	3	Key 8 x 7 x 50 mm
27	121 150 237	2	
28	121 150 238	1	
29	100 323 144	2	Disc washer 70 x 40.5 x 4 mm
30	121 130 226	1	
31	100 407 025	1	Star washer MB 8
32	100 323 064	1	Ring nut KM 8
35	121 130 253	1	
36	100 316 075	20	Flange nut M6
38	100 323 398	18	Flange set screw M6 x 16 mm
39	121 100 303	-	Sealing strip. Indicate length 8.3 m when ordering
40	121 150 166	3	
41	100 316 075	21	Flange nut M6
43	121 120 385	1	
44	100 323 398	20	Flange set screw M6 x 16 mm
45	100 311 017	8	Coach bolt M8 x 25 mm
46	100 323 398	21	Flange set screw M6 x 16 mm
47	121 120 384	1	
48	100 331 005	8	Flat washer M8
49	100 316 003	8	Lock nut M8
52	100 306 001	4	Set screw M6 x 20 mm
53	121 150 257	2	
55	100 315 028	4	Nut M6
57	121 150 182	8	Flat washer
58	121 120 386	1	
59	100 306 001	6	Set screw M6 x 20 mm
61	100 316 075	18	Flange nut M6
62	100 203 030	-	Sealing strip 2 x 6 mm. Indicate length 1.6 m when ordering
63	121 130 131	1	
64	121 130 255	1	
65	100 331 004	6	Flat washer M6
66	100 316 002	6	Lock nut M6
68	122 000 857	1	Clamp OK160 with screw
69	110 101 105	1	
70	100 332 002	6	Star washer M6
71	100 308 018	6	Set screw M6 x 12 mm
72	121 130 257	1	
73	100 413 066	1	O-ring 84.2 x 5.7 mm
74	121 134 376	1	
75	121 150 243	1	
76	100 401 072	1	Ball bearing # 6208 - 2RS1/C3HT51
77	121 130 042	1	
Cpl.	121 130 132	1	Complete incl. items 1 - 77

# SUC 500 T2/TR2

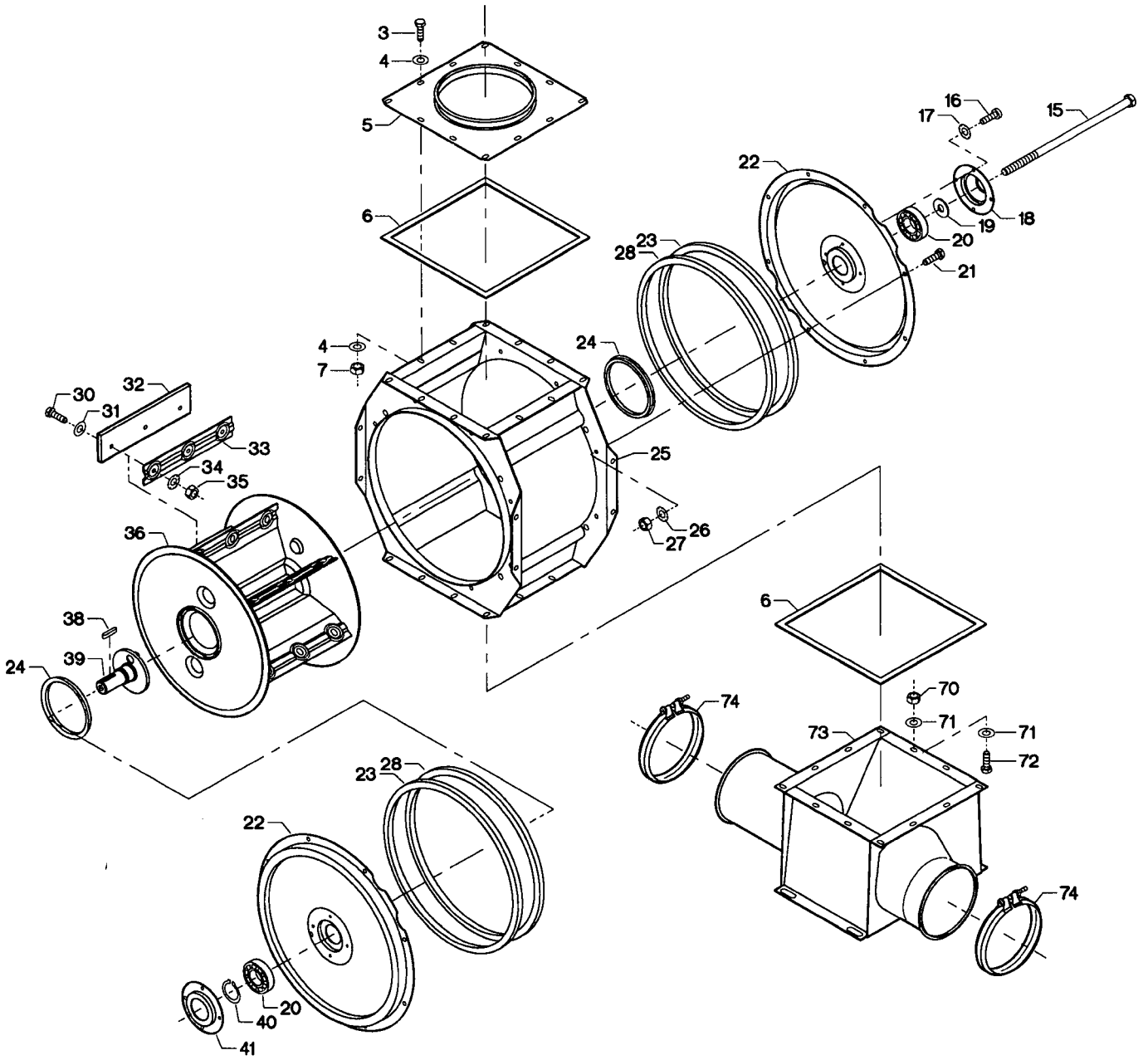

Fig.	Part no.	Pieces	Notes	
3	100 306 014	12	Set screw M8 x 15/16 mm	
4	100 331 005	24	Flat washer M8	
5	121 108 235	1	7 x 8 mm. Order 2.2 m	
6	100 202 011	-		
7	100 315 012	12		Nut M8
15	100 302 054	1	Bolt M16 x 320 mm	
16	100 321 013	8	Torx screw M6 x 10 mm	
17	100 332 002	8	Star washer M6	
18	121 109 090	1		
19	121 108 135	1		
20	100 401 003	2	Ball bearing # 6207-2RS1	
21	100 306 014	16	Set screw M8 x 15/16 mm	
22	121 109 088	2		
23	121 100 349	2		
24	100 413 069	2		
25	121 108 232	1	Star washer M8	
26	100 332 003	16		
27	100 315 012	16	Nut M8	
28	121 100 368	2	Set screw M8 x 25 mm	
30	100 308 002	18		
31	100 331 096	18	Flat washer M8	
32	121 108 007	6		
33	121 108 136	6	Star washer M8	
34	100 332 003	18		
35	100 315 012	18		Nut M8
36	121 108 215	1	Complete incl. items 30 - 36	
Cpl:	121 108 117	1		
38	100 405 015	1		Key 8 x 7 x 36 mm
39	121 108 224	1		Circlip ø35 x 1.5 mm
40	100 407 009	1		
41	121 109 089	1	Complete incl. items 15 - 41	
Cpl:	121 108 121	1		
70	100 315 012	12		Nut M8
71	100 331 005	24		Flat washer M8
72	100 306 014	12		Set screw M8 x 15/16 mm
73	121 108 243	1	Bolt clamp OK160, for spec. safety joint	
74	122 001 078	2		

# SUC 500 T2/TR2

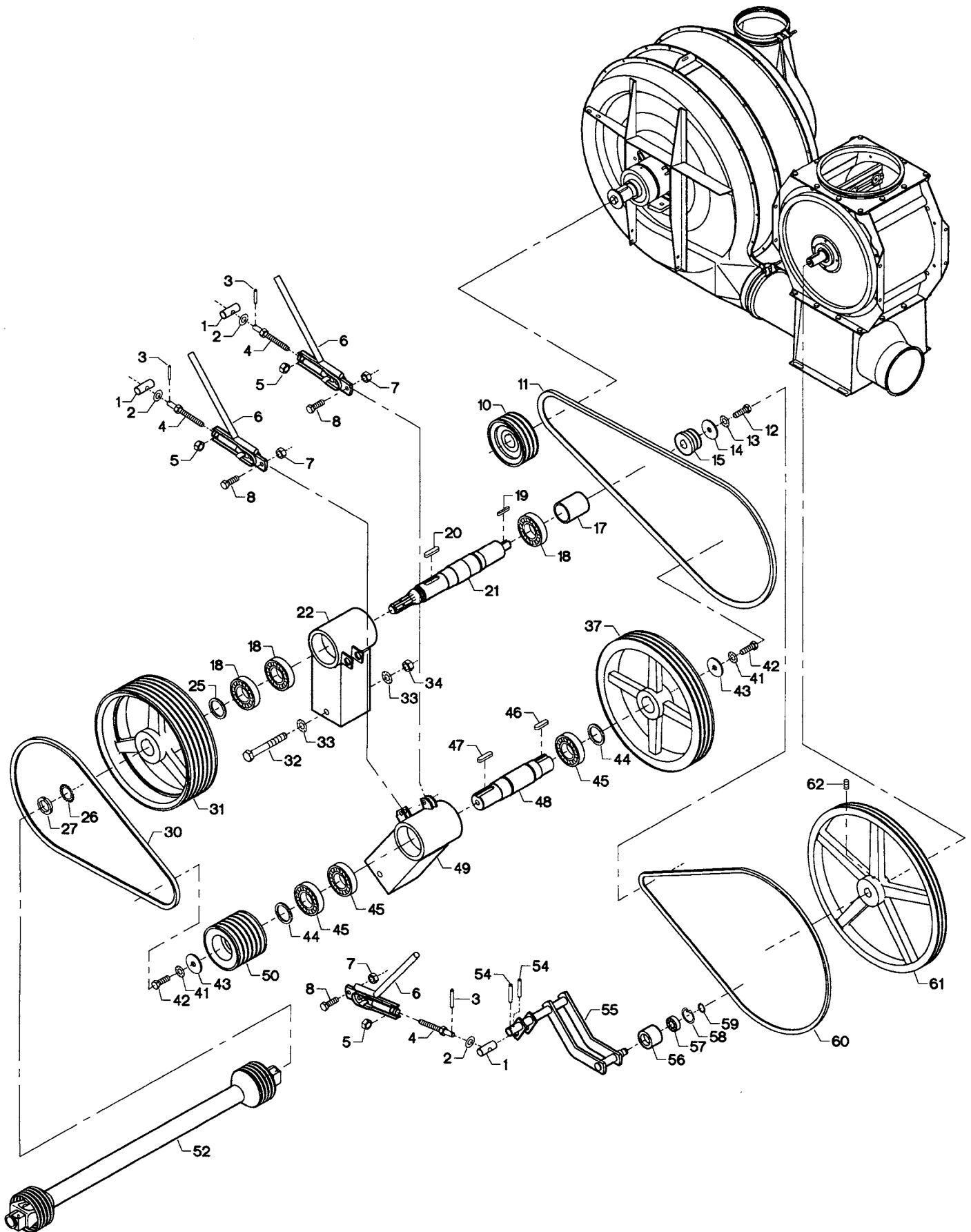

Fig.	Part no.	Pieces	Notes
1	121 131 285	3	Flat washer M16 Slottet spring pin $\varnothing 6 \times 32$ mm Nut M16
2	100 331 008	3	
3	100 333 018	3	
4	121 131 129	3	
5	100 315 020	3	
6	121 131 115	3	Lock nut M12 Set screw M12 x 40 mm V-belt pulley SPB 150 with 3 grooves Raw edge moulded notch V-belt SPB 2500, set 3
7	100 316 005	3	
8	100 306 044	3	
10	121 131 063	1	
11	100 403 086	3	
12	100 304 044	1	Set screw M16 x 30 mm Star washer M16 V-belt pulley SPA 63 with 2 grooves, bore $\varnothing 28$ mm
13	100 332 006	1	
14	121 121 079	1	
15	121 131 224	1	
17	121 131 280	1	
18	100 401 013	3	Ball bearing # 6212 - 2 RS1 Key 8 x 7 x 36 mm Key 16 x 10 x 63 mm
19	100 405 015	1	
20	100 405 010	1	
21	121 131 276	1	
22	121 131 204	1	
25	121 131 288	1	Star washer MB10 Ring nut KM10 Complete incl. items 12 - 27 Raw edge moulded notch V-belt SPB 1800, set 6
26	100 407 024	1	
27	100 323 063	1	
Cpl:	121 131 202	1	
30	100 403 022	6	
31	121 131 059	1	V-belt pulley SPB 400 with 6 grooves Bolt with nut M20 x 160 mm Star washer M20 Nut M20 V-belt pulley SPB 450 with 3 grooves
32	100 302 042	2	
33	100 332 007	4	
34	100 315 019	2	
37	121 131 061	1	
41	100 332 006	2	Star washer M16 Set screw M16 x 30 mm Ball bearing # 6212 - 2 RS1
42	100 304 044	2	
43	121 121 079	2	
44	121 131 288	2	
45	100 401 013	3	
46	100 405 012	1	Key 16 x 10 x 50 mm Key 16 x 10 x 63 mm Complete incl. items 41 - 49
47	100 405 010	1	
48	121 131 277	1	
49	121 131 208	1	
Cpl:	121 131 201	1	
50	121 131 060	1	V-belt pulley SPB 140 with 6 grooves P.T.O. shaft Slottet spring pin $\varnothing 6 \times 32$ mm
52	199 073 163	1	
54	100 333 018	2	
55	121 131 124	1	
56	121 108 223	1	
57	100 401 006	1	Ball bearing # 6304 - 2RS Circlip $\varnothing 52 \times 2.0$ mm Circlip $\varnothing 20 \times 1.2$ mm Raw edge moulded notch V-belt SPA 2070 RE, set 2 V-belt pulley SPA 560 with 2 grooves
58	100 407 019	1	
59	100 407 011	1	
60	100 403 015	2	
61	121 131 062	1	
62	100 322 005	1	Stop screw M10 x 15 mm

# SUC 500 T2/TR2

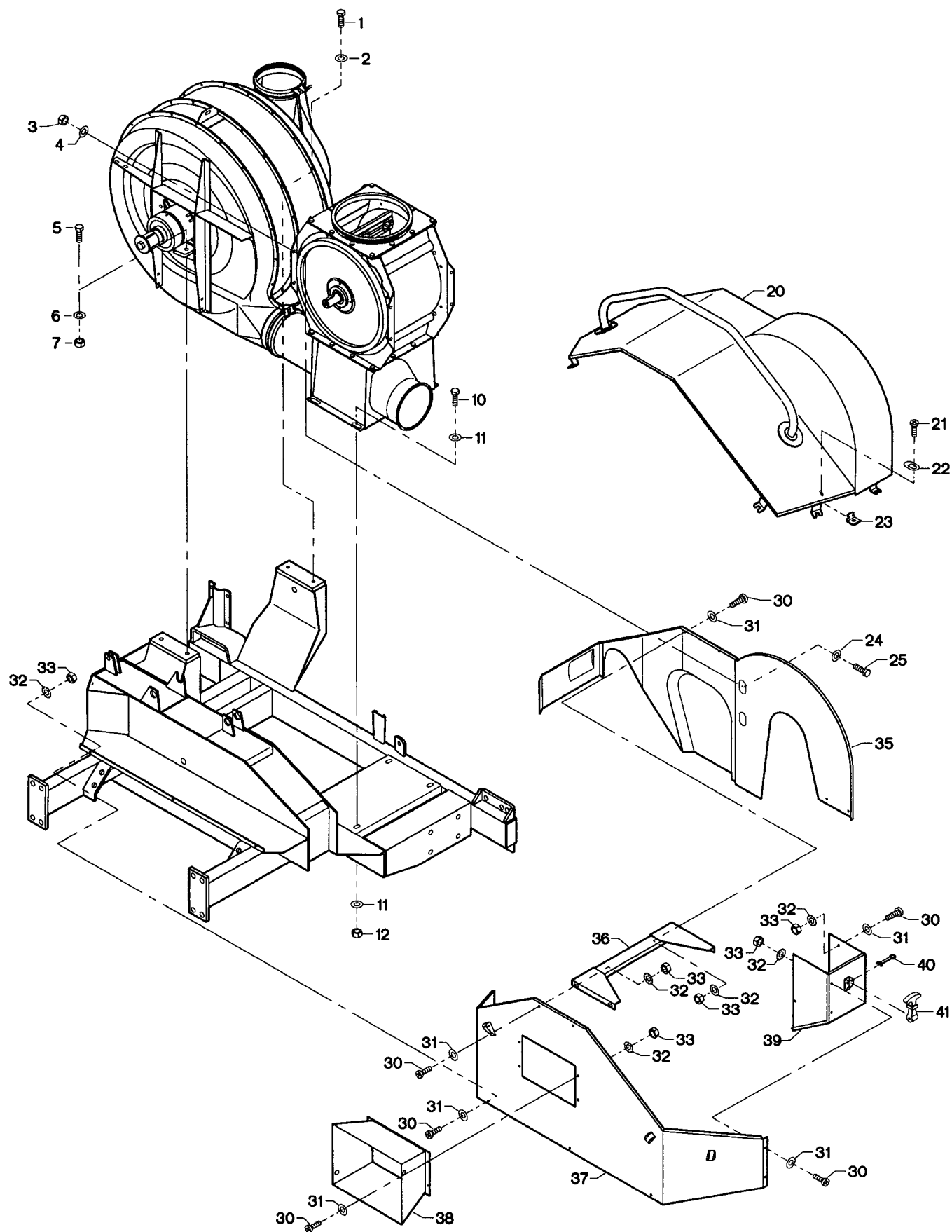



Fig.		Part no.	Pieces	Notes
1		100 306 042	2	Set screw M12 x 25 mm
2		100 331 007	2	Flat washer M12
3		100 315 012	2	Nut M8
4		100 332 003	2	Star washer M8
5		100 304 033	2	Set screw M12 x 35 mm
6		100 332 005	2	Star washer M12
7		100 315 016	2	Nut M12
10		100 306 042	4	Set screw M12 x 25 mm
11		100 331 007	8	Flat washer M12
12		100 316 005	4	Lock nut M12
20		121 131 266	1	
21		100 321 010	2	Torx screw M5 x 12 mm
22		121 000 686	1	
23		121 000 402	1	
24		100 331 005	2	Flat washer M8
25		100 306 015	2	Set screw M8 x 20 mm
30		100 321 015	21	Torx screw M6 x 15/16 mm
31		100 331 004	21	Flat washer M6
32		100 332 002	21	star washer M6
33		100 315 028	21	Nut M6
35		121 131 263	1	
36		121 131 265	1	
37		121 131 262	1	
38		121 131 261	1	
39		121 131 264	1	
40		100 333 004	5	Split pin M5 x 30 mm
41		121 131 191	5	

# SUC 500 T2/TR2

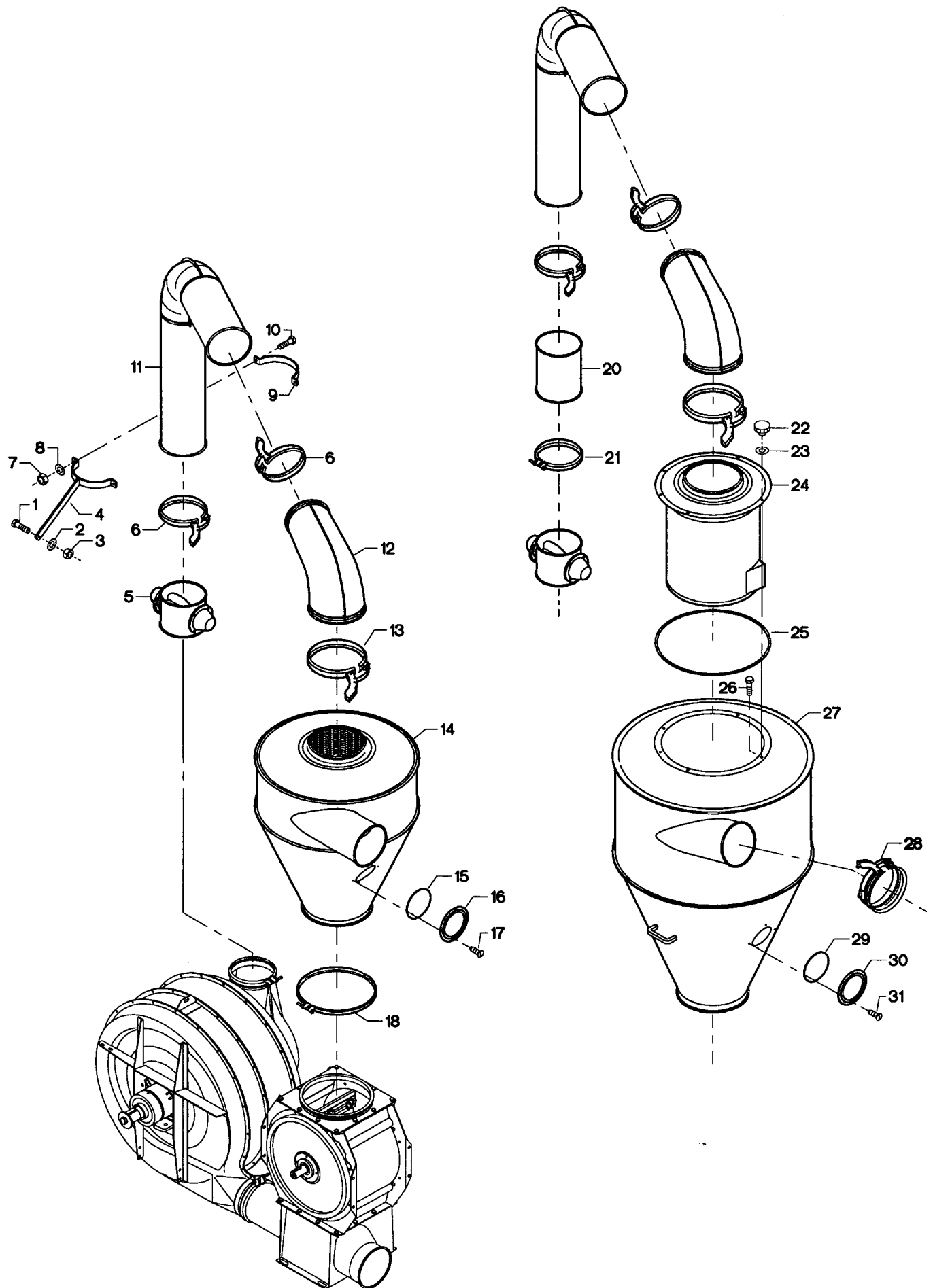

Fig.	Part no.	Pieces	Notes
1	100 308 002	1	Set screw M8 x 25 mm Star washer M8 Nut M8
2	100 332 003	1	
3	100 315 012	1	
4	121 131 268	1	
5	121 150 186	1	
6	122 000 825	1	Quick release clamp OKR160 Nut M8 Star washer M8 Set screw M8 x 35 mm
7	100 315 012	2	
8	100 332 003	2	
9	121 140 174	1	
10	100 308 032	2	
11	121 131 289	1	Quick release clamp OK200
12	121 140 175	1	
13	122 050 077	1	
15	121 000 090	1	
16	121 000 089	1	
17 Cpl:	100 323 011	4	Self-tapping screw # 8 x 5/16" S.C. Cyclon complete. Incl. items 14 - 17 Bolt clamp OK250
18	121 130 262	1	
20	122 000 603	1	
21	121 130 238	1	
21	122 000 857	1	
22	100 414 050	5	Star handle M8 Flat washer M8 Sealing strip. Indicate length 1.3 m when ordering Set screw M8 x 25 mm
23	100 331 014	5	
24	121 150 260	1	
25	121 100 303	-	
26	100 308 002	5	
27	121 141 093	1	Clamp with bolt OK160 Self-tapping screw # 8 x 5/16"
28	122 000 716	1	
29	121 000 090	1	
30	121 000 089	1	
31	100 323 011	4	
Cpl:	121 141 095	1	Cyclon Ø700 complete. Incl. items 22 - 31

# SUC 500 T2/TR2

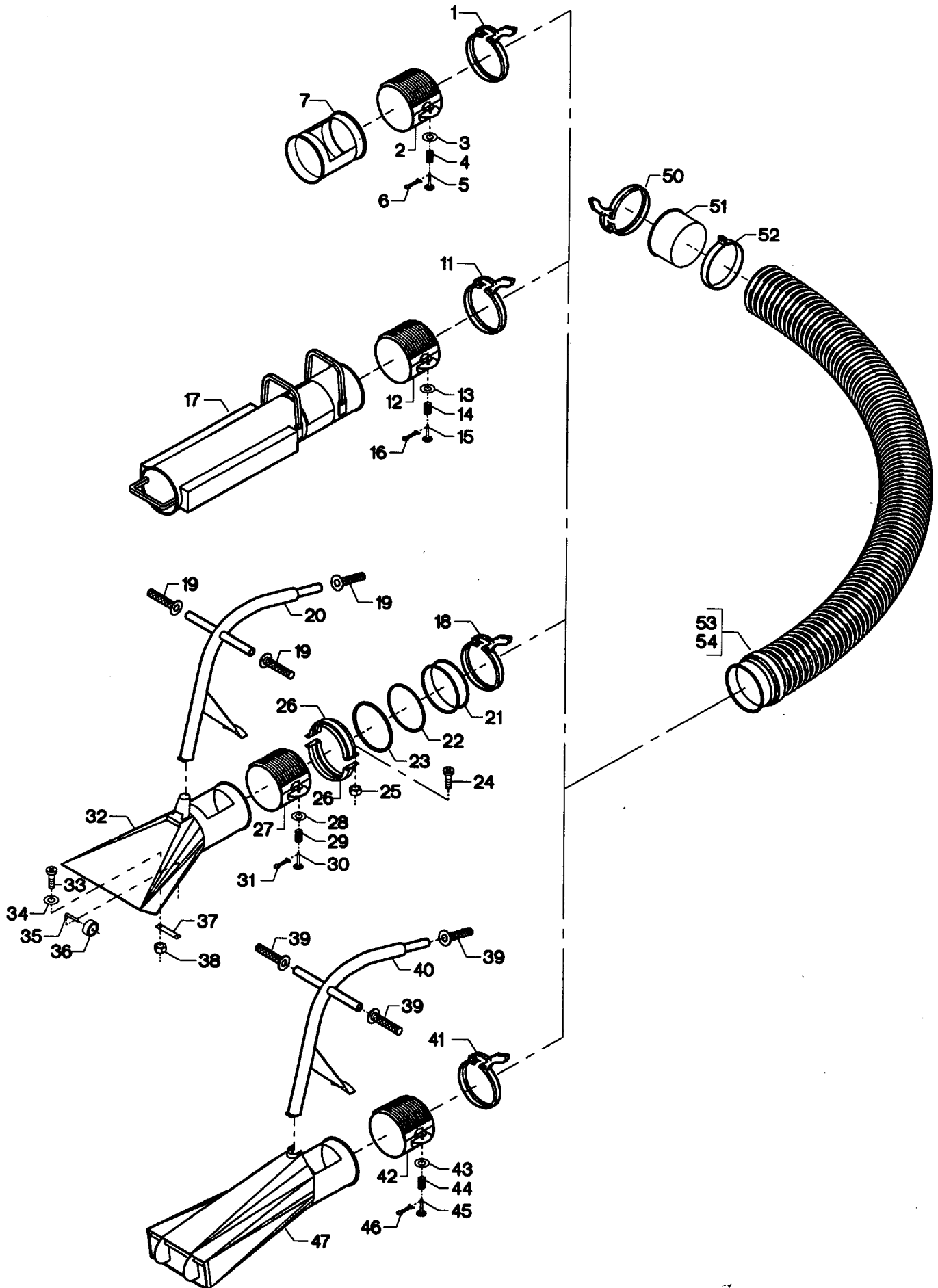

Fig.	Part no.	Pieces	Notes
1	122 000 825	1	Quick release clamp OKR160
2	121 130 100	1	
3	100 331 013	1	Flat washer M6
4	121 120 116	1	
5	121 120 113	1	
6	100 333 000	1	Split pin $\varnothing 2 \times 15$ mm
7	121 000 744	1	
Cpl:	121 000 732	1	Suction head complete incl. items 1 - 7
11	122 000 825	1	Quick release clamp OKR160
12	121 130 100	1	
13	100 331 013	1	Flat washer M6
14	121 120 116	1	
15	121 120 113	1	
16	100 333 000	1	Split pin $\varnothing 2 \times 15$ mm
17	121 130 248	1	
Cpl:	121 130 213	1	Suction head complete incl. items 11 - 17
18	122 000 825	1	Quick release clamp OKR160
19	100 414 016	3	
Cpl:	121 130 273	1	Handle complete incl. items 19 + 20
21	121 130 199	1	
22	121 130 197	1	O-ring
23	121 130 236	1	Sealing ring
24	100 321 015	2	Torx screw M6 x 15 mm
25	100 316 002	2	Lock nut M6
26	121 130 198	2	
27	121 130 100	1	
28	100 331 013	1	Flat washer M6
29	121 120 116	1	
30	121 120 113	1	
31	100 333 000	1	Split pin $\varnothing 2 \times 15$ mm
32	121 130 188	1	
33	100 321 013	2	Torx screw M6 x 10 mm
34	100 331 004	2	Flat washer M6
35	121 130 211	2	
36	100 412 006	2	
37	121 130 210	2	
38	100 315 028	2	Nut M6
Cpl:	121 130 265	1	Suction head complete incl. items: 19 - 38
39	100 414 016	3	
40	121 130 246	1	
41	122 000 825	1	Quick release clamp OKR160
42	121 130 100	1	
43	100 331 013	1	Flat washer M6
44	121 120 116	1	
45	121 120 113	1	
46	100 333 000	1	Split pin $\varnothing 2 \times 15$ mm
47	121 130 266	1	
Cpl:	121 130 247	1	Suction head complete incl. items: 39 - 47
50	122 000 825	1	Quick release clamp OKR160
51	121 000 775	2	
52	100 420 172	2	Clamp
Cpl:	121 000 645	1	Suction pipe 2.6 m complete incl. items: 50 + 51 + 52 + 53
Cpl:	121 000 650	1	Suction pipe 3.8 m complete incl. items: 50 + 51 + 52 + 54

# SUC 500 T2/TR2

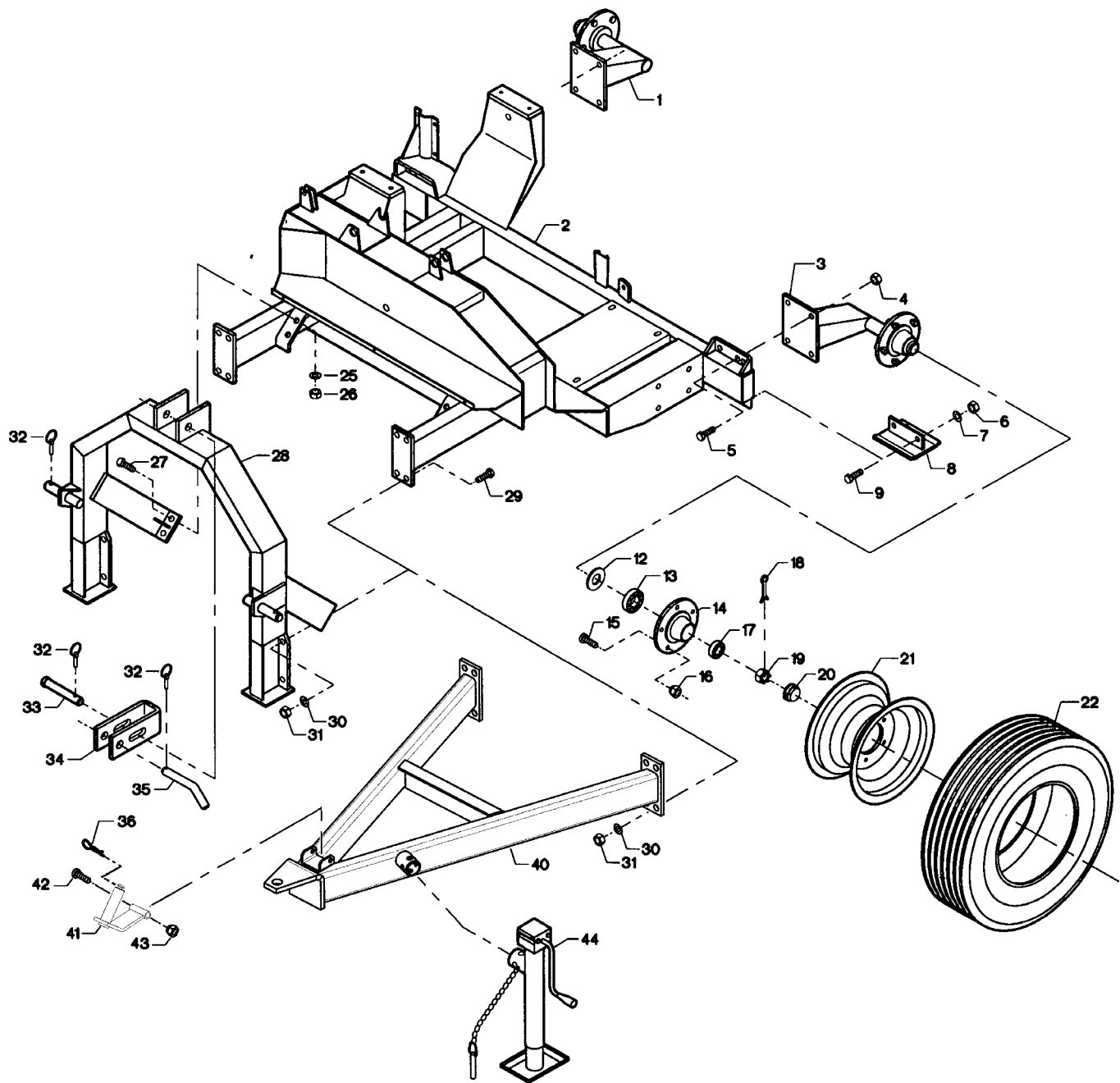

Fig.	Part no.	Pieces	Notes
1	121 134 343	1	
2	121 134 131	1	
3	121 134 344	1	
4	100 316 006	8	Lock nut M16
5	100 306 055	8	Set screw M16 x 40 mm
6	100 315 020	4	Nut M16
7	100 332 006	4	Star washer M16
8	121 131 247	2	
9	100 306 056	4	Set screw M16 x 45 mm
12	100 423 092	1	Seal cover ø72/42 mm
13	100 402 001	1	Bearing # 30207
15	100 323 365	5	Hub bolt M12 x 1.5 x 36 mm
16	100 316 087	5	Hub nut M12 x 1.5 mm - R12
17	100 402 000	1	Bearing # 30205
18	100 333 004	1	Split pin ø5 x 30 mm
19	100 316 086	1	Castle nut M16
20	100 423 093	1	Dust cap
Cpl:	121 134 188	2	Hub complete type FL 35 - 5. Incl. items 12-20
21	100 423 057	1	Rim 5.5k x 14 - 5 / 10Z / 140
22	100 423 096	1	Tyre 205/75 R14C 6 PR
Cpl:	121 000 782	2	Rim with tyre complete. incl. items 21+22
25	100 332 006	4	Star washer M16
26	100 315 020	4	Nut M16
27	100 306 056	4	Set screw M16 x 45 mm
28	121 131 245	1	
29	100 306 056	8	Set screw M16 x 45 mm
30	100 332 006	8	Star washer M16
31	100 315 020	8	Nut M16
32	100 333 014	4	Lynch pin ø 9.5 mm
33	105 000 665	1	
34	121 131 025	1	
35	105 000 388	1	
36	100 333 011	1	Hair pin clip ø4.0 mm
40	121 134 388	1	
41	121 165 608	1	
42	100 306 052	1	Bolt M12x100 mm
43	100 316 005	1	Lock nut M12
Cpl:	121 134 386	1	Complete incl. items 40 - 43
44	121 134 128	1	

# SUC 500 T2/TR2

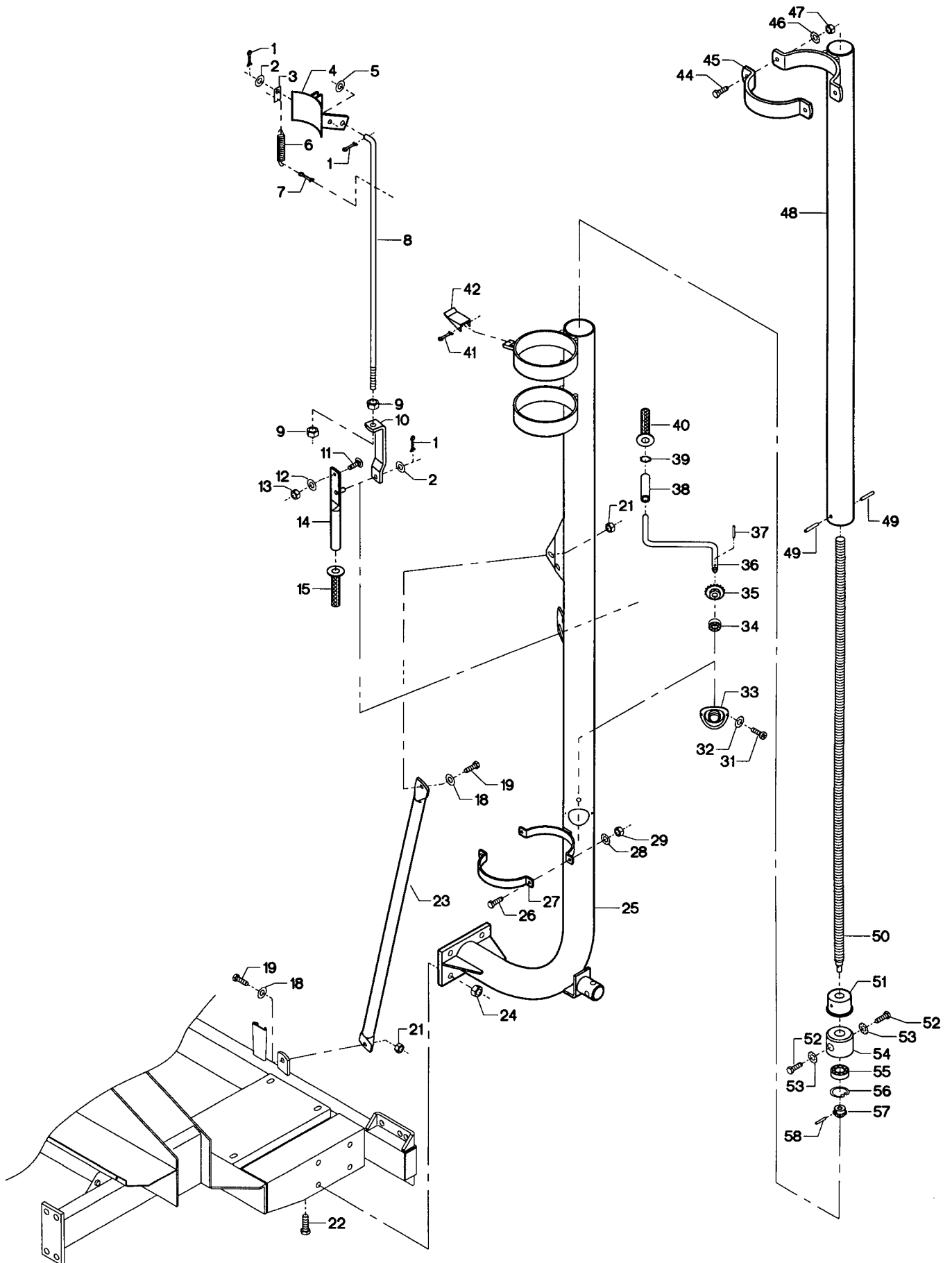



Fig.	Part no.	Pieces	Notes
1	100 333 002	3	Split pin $\varnothing 3$ x 30 mm
2	100 331 007	2	Flat washer M12
3	121 134 258	1	
4	121 134 164	1	
5	100 331 008	1	Flat washer M16
6	122 000 350	1	Spring $\varnothing 14$ mm
7	100 333 003	1	Split pin $\varnothing 4$ x 25 mm
8	121 134 234	1	
9	100 315 020	2	Nut M16
10	121 134 233	1	
11	100 311 030	1	Coach bolt M10 x 25 mm
12	100 331 006	1	Flat washer M10
13	100 316 004	1	Lock nut M10
14	121 134 286	1	
15	100 414 016	1	
18	100 331 007	2	Flat washer M12
19	100 304 033	2	Set screw M12 x 35 mm
21	100 316 005	2	Lock nut M12
22	100 306 057	4	Set screw M16 x 50 mm
23	121 134 224	1	
24	100 316 006	4	Lock nut M16
25	121 134 288	1	
26	100 308 032	2	Set screw M8 x 35 mm
27	121 140 174	1	
28	100 332 003	2	Star washer M8
29	100 315 012	2	Nut M8
31	100 321 013	2	Torx screw M6 x 10 mm
32	100 332 002	2	Star washer M6
33	121 134 207	1	
34	100 401 077	1	Ball bearing # 6200 - 2RS1/C3
35	121 134 202	1	
36	121 134 168	1	
37	100 333 018	1	Slotted spring pin $\varnothing 6$ x 32 mm
38	121 134 367	1	
39	100 407 028	1	Circlip $\varnothing 15$ x 1 mm
40	100 414 016	1	
41	100 333 035	1	Split pin $\varnothing 5$ x 30 mm
42	121 134 259	1	
44	100 304 033	2	Set screw M12 x 35 mm
45	121 134 177	1	
46	100 332 005	2	Star washer M12
47	100 315 016	2	Nut M12
48	121 134 172	1	
49	100 333 038	2	Slotted spring pin $\varnothing 8$ x 20 mm
50	121 134 370	1	
51	121 134 371	1	
52	100 306 043	2	Set screw M12 x 30 mm
53	100 332 005	2	Star washer M12
54	121 134 369	1	
55	100 401 006	1	Ball bearing # 6304 - 2RS
56	100 407 019	1	Circlip $\varnothing 52$ x 2 mm
57	121 134 203	1	
58	100 333 018	1	Slotted spring pin $\varnothing 6$ x 32 mm

# SUC 500 T2/TR2

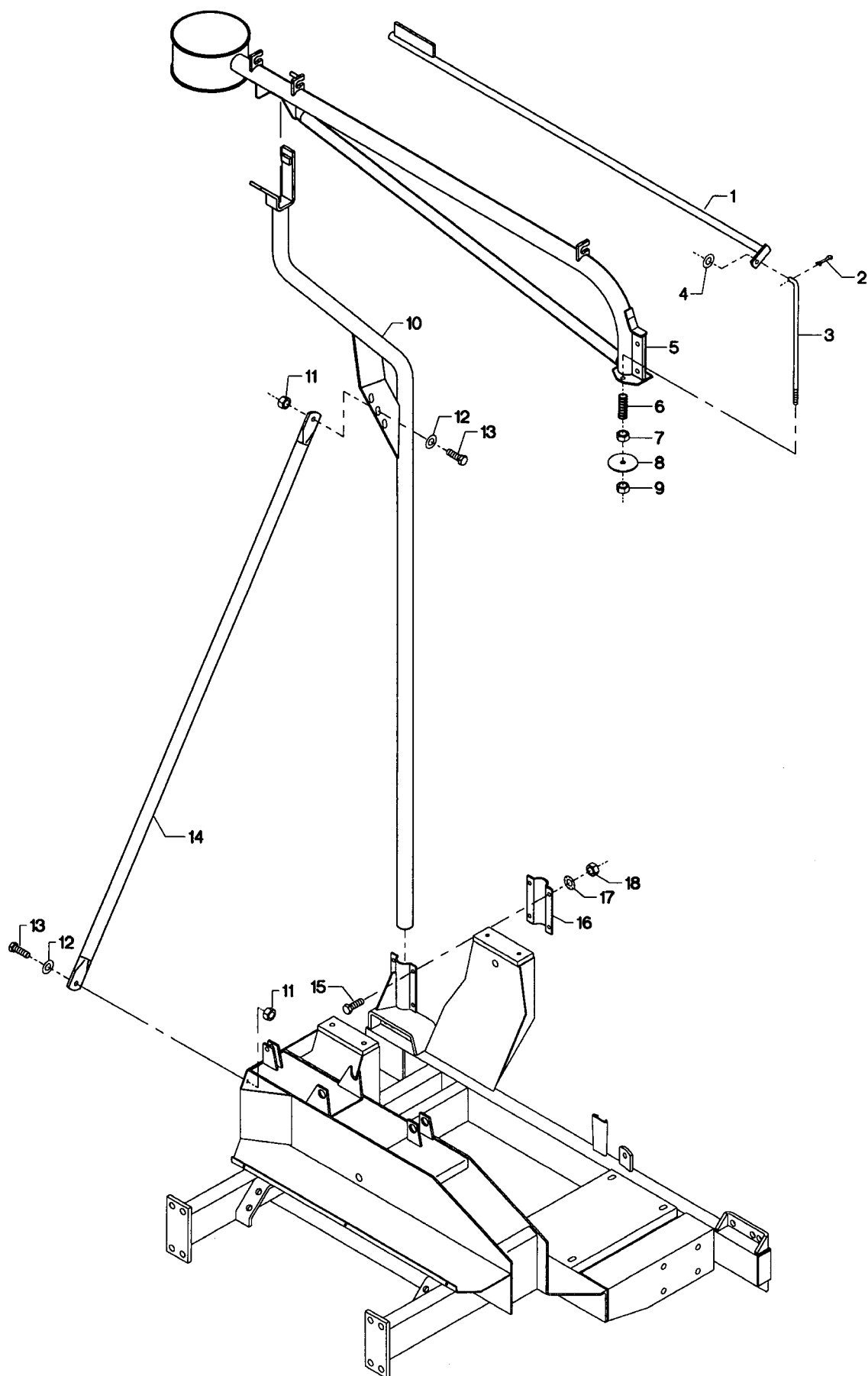

Fig.		Part no.	Pieces	Notes
1		121 134 236	1	
2		100 333 001	1	Split pin $\varnothing 3 \times 20$ mm
3		121 134 386	1	
4		100 331 007	1	Flat washer M12
5		121 134 149	1	
6		121 134 244	1	
7		100 315 016	1	Nut M12
8		121 141 043	1	
9		100 316 005	1	Lock nut M12
10		121 141 016	1	
11		100 316 005	2	Lock nut M12
12		100 331 007	2	Flat washer M12
13		100 304 033	2	Set screw M12 x 35 mm
14		121 134 224	1	
15		100 306 029	4	Set screw M10 x 25 mm
16		121 134 142	1	
17		100 332 004	4	Star washer M10
18		100 315 013	4	Nut M10

# SUC 500 T2/TR2

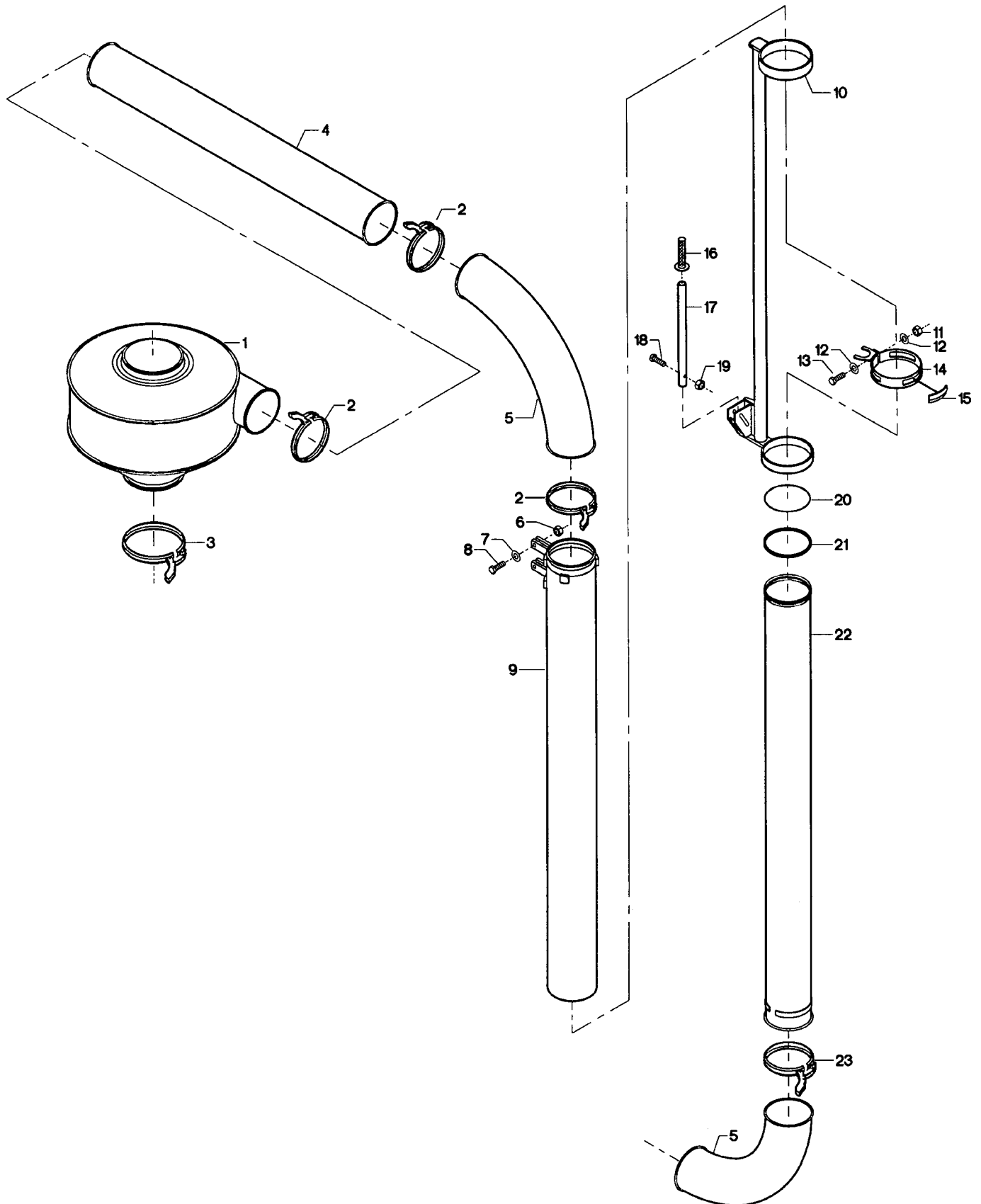
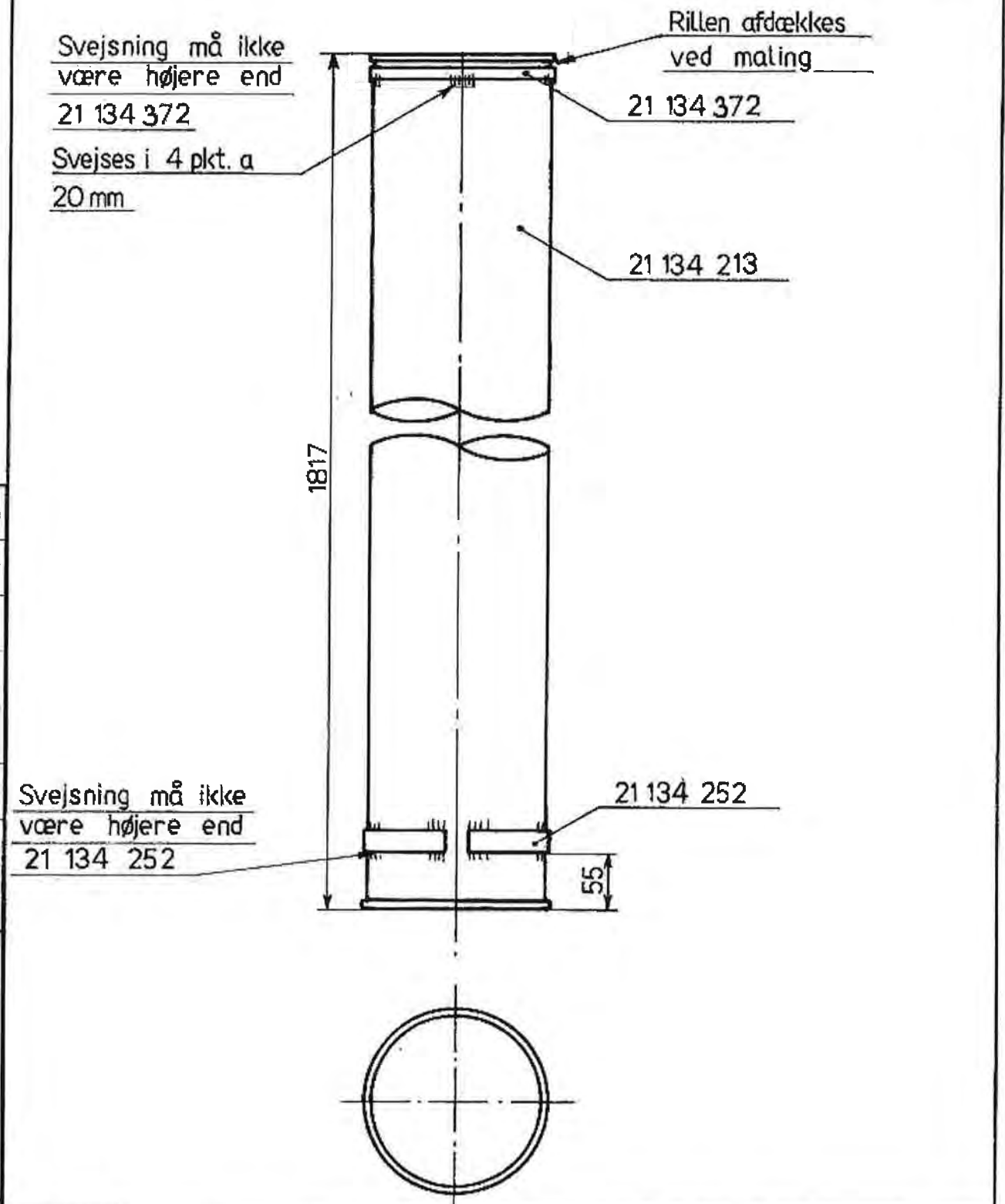

Fig.	Part no.	Pieces	Notes
1	122 000 872	1	UC cyclon OK160/OK200
2	122 000 825	3	Quick release clamp OKR160
3	122 050 077	1	Quick release clamp OK200
4	122 010 058	1	Pipe OKD160, 1.0 m
5	122 020 169	2	Bend 90° OKR160
6	100 316 005	2	Lock nut M12
7	100 331 007	2	Flat washer M12
8	100 308 015	2	Set screw M12 x 45 mm
9	121 134 156	1	
10	121 134 143	1	
11	100 315 013	1	Nut M10
12	100 331 015	2	Flat washer M10
13	100 304 024	1	Set screw M10 x 35 mm
14	121 150 046	1	
15	121 150 239	3	
16	100 414 016	1	
17	121 134 221	1	
18	100 304 027	1	Set screw M10 x 50 mm
19	100 316 004	1	Lock nut M10
20	121 134 309	1	Spring
21	121 134 373	1	
22	121 134 308	1	
23	122 000 825	1	Quick release clamp OKR160



Tolerance	Afvigelse



Orig.: 01	T-kopli:	Kontrol:		
		14,76 kg	Males: Spaceblue	
Materialer	Vægt	Overfladebehandling	Værktøj nr.	
LÆSSEUDSTYR F. SUGETRYKBL.	Målforshold	Tegn.	4/3-86 SUS	(Erstatning for:) 21 134 212
Inderste teleskoprør m. tætn. sv.	1 : 5	Kontr.	5/8 86 20K	
				(Erstatlet af:)

# SUC 500 T2/TR2





