

SUC 100 & 150 E

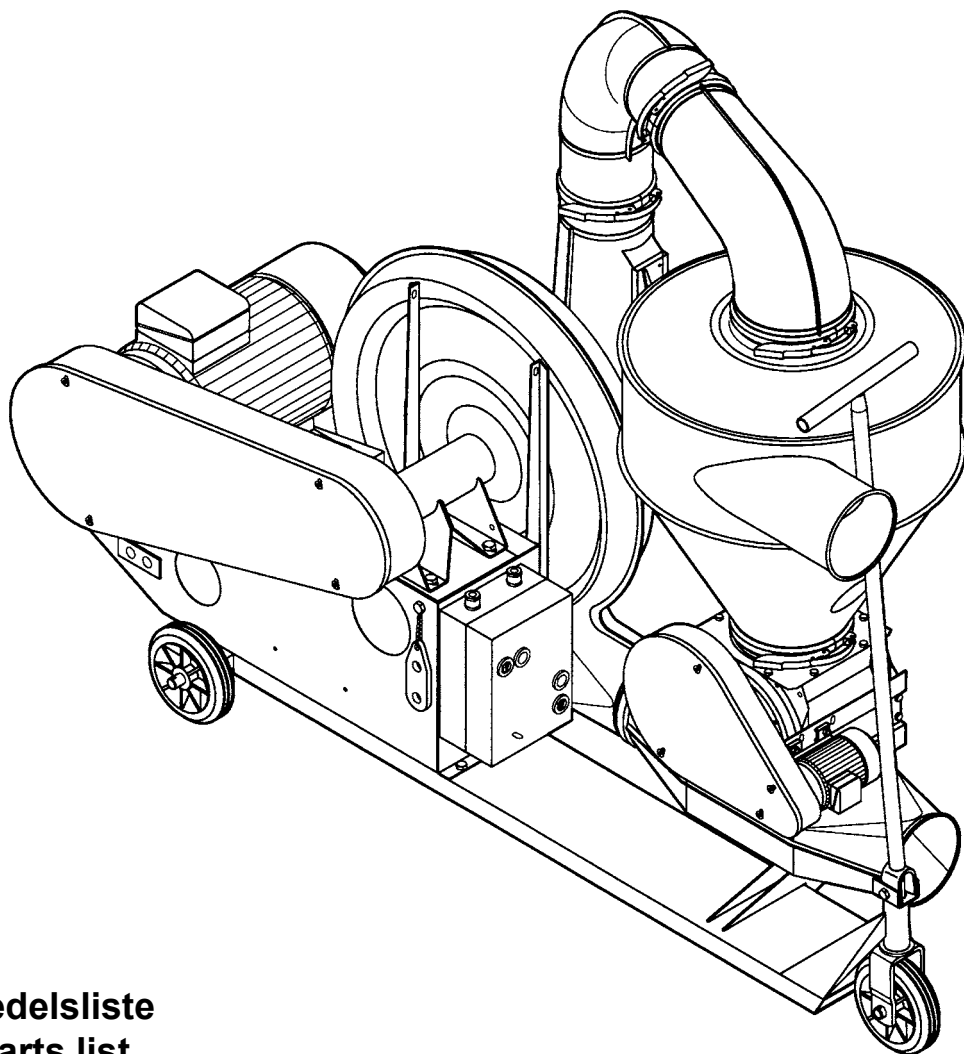

Reservedelsliste
Spare parts list
Ersatzteilliste
Onderdelenlijst
Liste de pièce de rechange
Lista dei pezzi di ricambio

SUC 100 E

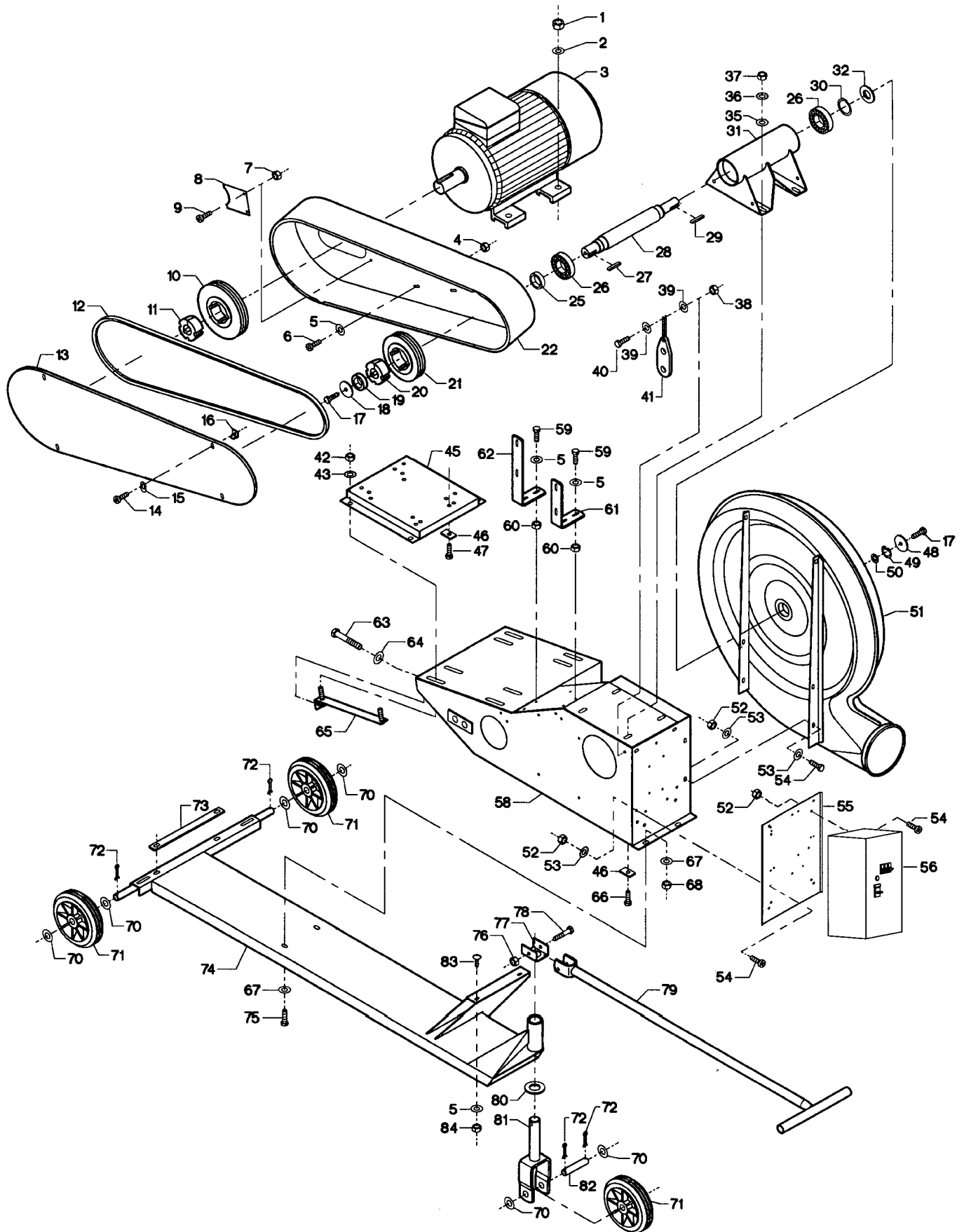

Fig.	Part no.	Pieces	Notes
1	100 315 013	4	Nut M10
2	100 331 006	4	Flat washer M10
3	100 501 064	1	Motor 132SX2 - B3 - 7.5 KW - 3x400 V - 50 Hz
4	100 316 075	4	Flanged nut M6
5	100 331 004	10	Flat washer M6
6	100 321 015	4	Torx screw M6 x 16 mm
7	100 316 002	2	Lock nut M6
8	121 075 062	1	
9	100 321 013	2	Torx screw M6 x 10 mm
10	121 075 061	1	V-belt pulley SPZ 165 with 3 grooves, TB-2012
11	123 000 468	1	TB-2012-38
12	100 403 241	3	Raw edge moulded notch V-belt SPZ-1787
13	121 123 232	1	
14	100 321 010	4	Torx screw M5 x 12 mm
15	121 000 686	4	
16	121 000 402	4	
17	100 306 030	2	Set screw M10 x 30 mm
18	121 000 060	1	Flat washer ϕ 53/11 x 3 mm
19	123 000 378	1	Spacer
20	123 000 183	1	TB-2012-32
21	121 081 164	1	V-belt pulley SPZ 132 with 3 grooves, TB-2012
22	121 081 170	1	
25	113 026 064	1	Spacer
26	100 401 072	2	Ball bearing # 6208 - 2RS1/C3HT51
27	100 405 014	1	Key 10 x 8 x 28 mm
28	113 026 063	1	
29	100 405 015	1	Key 8 x 7 x 36 mm
30	100 407 012	1	Circlip ϕ 40 x 1.75 mm
31	113 026 067	1	
Cpl:	121 090 044	1	Incl. Fig. 25 - 31
32	121 090 038	4	Sealing ring
35	100 331 006	4	Flat washer M10
36	100 332 004	4	Star washer M10
37	100 315 013	4	Nut M10
38	100 316 002	1	Lock nut M6
39	100 331 004	2	Flat washer M6
40	100 308 025	1	Set screw M6 x 25 mm
41	100 511 000	1	Unloading clamp
42	100 315 016	4	Nut M12
43	100 332 005	4	Star washer M12
45	121 066 029	1	
46	121 000 058	8	Washer 25 x 40 x 5 mm/ ϕ 11 mm
47	100 308 037	4	Set screw M10 x 40 mm
48	121 000 060	1	Flat washer ϕ 53/11 x 3 mm
49	100 407 001	1	Circlip ϕ 28 x 1.2 mm
50	121 000 027	1	Flat washer ϕ 27.8/17 x 2 mm
51	121 090 047	1	
52	100 316 003	12	Lock nut M8
53	100 331 005	12	Flat washer M8
54	100 306 014	12	Set screw M8 x 16 mm
55	121 089 126	1	
56	100 503 131	1	Motor control, 3x400 V - 7.5 kW + 0.55/0.75 kW
58	121 081 142	1	
59	100 308 025	4	Set screw M6 x 20 mm
60	100 316 002	4	Lock nut M6
61	121 081 179	1	
62	121 081 180	1	
63	100 308 017	2	Set screw M12 x 130 mm
64	100 331 007	2	Flat washer M12
65	121 080 133	2	
66	100 306 029	4	Set screw M10 x 25 mm
67	100 331 006	8	Flat washer M10
68	100 315 013	4	Nut M10
70	100 331 009	6	Flat washer M20
71	100 412 007	3	Wheel MA-EN 508 55/20-200/50
72	100 333 004	4	Split pin ϕ 5 x 30 mm
73	121 083 025	1	
74	121 089 102	1	
75	100 308 004	4	Set screw M10 x 20 mm
76	100 316 004	1	Lock nut M10
77	121 132 066	1	
78	100 306 037	1	Bolt M10 x 65 mm
79	121 132 067	1	
80	100 323 020	1	Flat washer ϕ 60/33 x 5 mm
81	121 089 103	1	
82	121 089 101	1	
83	100 311 000	2	Coach bolt M6 x 15 mm
84	100 315 028	2	Nut M6

SUC 150 E

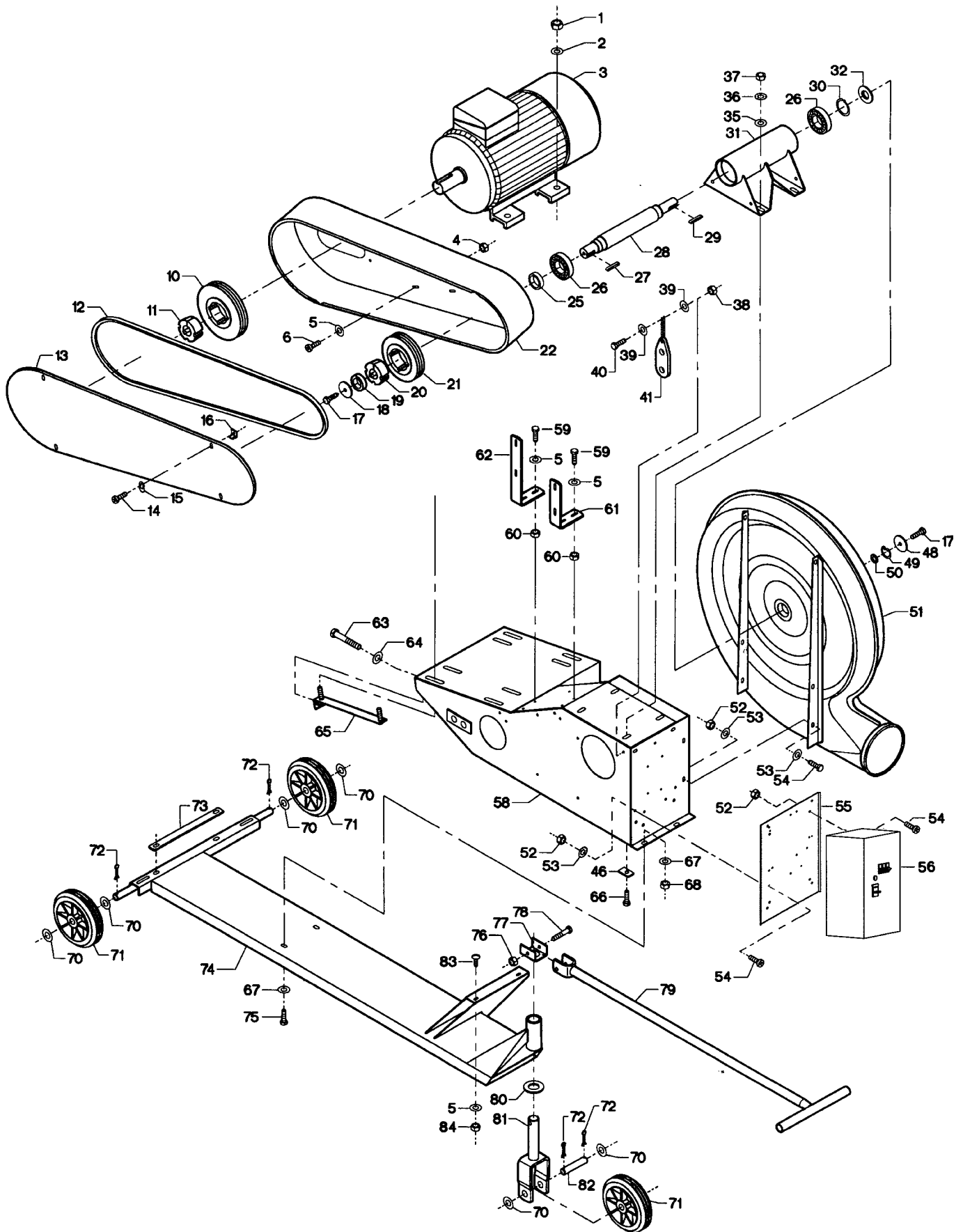

Fig.	Part no.	Pieces	Notes
1	100 315 016	4	Nut M12
2	100 332 005	4	Star washer M12
3	100 501 019	1	Motor 160 M2, 11 KW, B3
	100 501 213	1	Motor 3500RPM, 11 KW, B3, 3 x 240V, 60 Hz
4	100 316 075	4	Flanget nut M6
5	100 331 004	10	Flat washer M6
6	100 321 015	4	Torx screw M6 x 15 mm
10	121 081 167	1	V-belt pulley SPZ 200 with 3 grooves, TB-2012
11	123 000 471	1	TB-2012-42
12	100 403 241	3	Raw edge moulded notch V-belt SPZ-1787
13	121 123 232	1	
14	100 321 010	7	Torx screw M5 x 12 mm
15	121 000 686	4	
16	121 000 402	4	
17	100 306 030	2	Set screw M10 x 30 mm
18	121 000 060	1	Flat washer $\varnothing 53/11$ x 3 mm
19	123 000 378	1	Spacer
20	123 000 183	1	TB-2012-32
21	121 081 164	1	V-belt pulley SPZ 132 with 3 grooves, TB-2012
	121 075 061	1	V-belt pulley SPZ 165 with 3 grooves, TB-2012, 60 Hz
22	121 081 170	1	
25	113 026 064	1	Spacer
26	100 401 072	2	Ball bearing # 6208 - 2RS1/C3HT51
27	100 405 014	1	Key 10 x 8 x 28 mm
28	113 026 063	1	
29	100 405 015	1	Key 8 x 7 x 36 mm
30	100 407 012	1	Circlip $\varnothing 40$ x 1.75 mm
31	113 026 067	1	
Cpl:	121 090 044	1	Incl. Fig. 25 - 31
32	121 090 038	4	Sealing ring
35	100 331 006	4	Flat washer M10
36	100 332 004	4	Star washer
37	100 315 013	4	Nut M10
38	100 316 002	1	Lock nut M6
39	100 331 004	2	Flat washer M6
40	100 308 025	1	Set screw M6 x 25 mm
41	100 511 000	1	Unloading clamp
46	121 000 058	4	Washer 25 x 40 x 5 mm/ $\varnothing 11$ mm
48	121 000 060	1	Flat washer $\varnothing 53/11$ x 3 mm
49	100 407 001	1	Circlip $\varnothing 28$ x 1.2 mm
50	121 000 027	1	Flat washer $\varnothing 27.8/17$ x 2 mm
51	121 081 154	1	
52	100 316 003	12	Lock nut M8
53	100 331 005	12	Flat washer M8
54	100 306 014	12	Set screw M8 x 15 mm
55	121 089 126	1	
56	100 503 132	1	Motor control, 3 x 400 v
58	121 081 142	1	
59	100 308 025	4	Set screw M6 x 25 mm
60	100 316 002	4	Lock nut M6
61	121 081 179	1	
62	121 081 180	1	
63	100 308 017	2	Set screw M12 x 130 mm
64	100 331 007	2	Flat washer M12
65	121 080 133	2	
66	100 306 029	4	Set screw M10 x 25 mm
67	100 331 006	8	Flat washer M10
68	100 315 013	4	Nut M10
70	100 331 009	6	Flat washer M20
71	100 412 007	3	Wheel MA-EN 508 55/20-200/50
72	100 333 004	4	Split pin $\varnothing 5$ x 30 mm
73	121 083 025	1	
74	121 089 102	1	
75	100 308 004	4	Set screw M10 x 20 mm
76	100 316 004	1	Lock nut M10
77	121 132 066	1	
78	100 306 037	1	Bolt M10 x 65 mm
79	121 132 067	1	
80	100 323 020	1	Flat washer $\varnothing 60/33$ x 5 mm
81	121 089 103	1	
82	121 089 101	1	
83	100 311 000	2	Coach bolt M6 x 15 mm
84	100 315 028	2	Nut M6

SUC 100 & 150 E

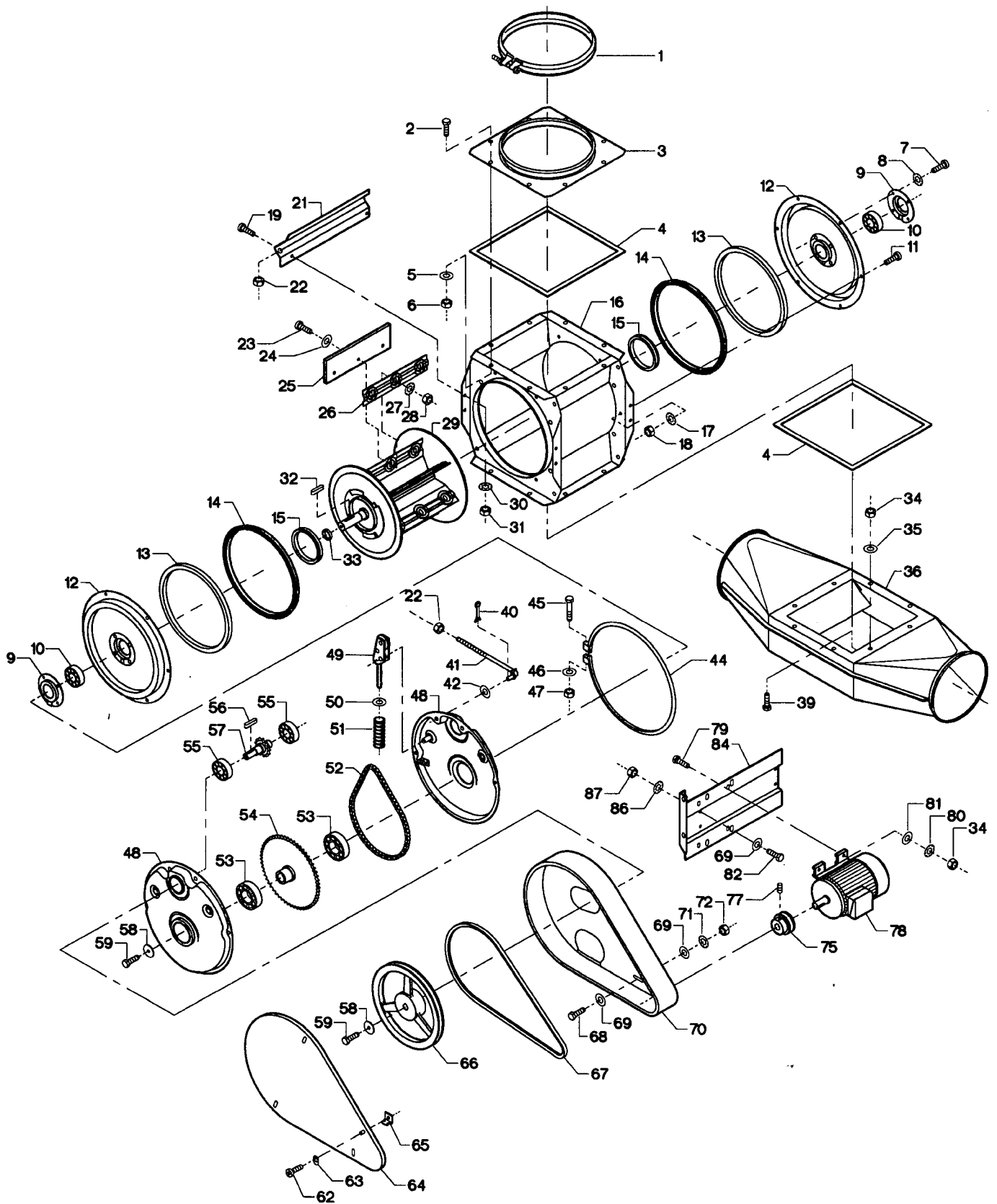

Fig.	Part no.	Pieces	Notes
1	122 050 237	1	Bolt clamp OK200, for spec. safety joint, Deltatone
2	100 306 014	8	Set screw M8 x 15 mm
3	121 100 422	1	Transition tube, OK200
4	100 202 011	-	Sealing strip 7 x 8 mm. Indicate length 1.4 m when ordering
5	100 331 005	8	Flat washer M8
6	100 315 012	8	Nut M8
7	100 321 013	8	Torx screw M6 x 10 mm
8	100 332 002	8	Star washer M6
9	121 100 186	2	Bearing cover
10	100 401 002	2	Ball bearing # 6204 - 2RS
11	100 321 014	12	Torx screw M6 x 12 mm
12	121 100 185	2	Rotary valve end casing
13	121 100 269	2	Sealing ring
14	121 100 365	2	Sealing ring
15	100 413 098	2	V-ring V-0080 A1
16	121 100 319	1	Casing
17	100 332 002	12	Star washer M6
18	100 315 028	12	Nut M6
19	100 321 015	2	Torx screw M6 x 12 mm
21	121 100 199	1	Belt tightener backstop
22	100 315 012	2	Nut M8
23	100 321 016	18	Torx screw M6 x 20 mm
24	100 331 004	18	Flat washer M6
25	121 100 210	6	Rotary wheel rubber blade
26	121 100 187	6	Clamp plate
27	100 332 002	18	Star washer M6
28	100 315 028	18	Nut M6
29	121 100 206	1	Rotary wheel
Cpl:	121 100 214	1	Rotary wheel complete with rubber blades, incl items 23 - 29
30	100 332 002	2	Star washer M6
31	100 315 028	2	Nut M6
32	100 405 019	1	Key 6 x 6 x 28 mm
33	121 100 370	1	Spacer
34	100 315 012	12	Nut M8
35	100 331 005	8	Flat washer M8
36	121 100 427	1	Discharge head
39	100 306 014	8	Set screw M8 x 16 mm
40	100 333 001	1	Split pin \varnothing 3 x 20 mm
41	121 100 196	1	Belt tightener
42	100 331 005	1	Flat washer M8
44	121 100 179	1	Clamp
45	100 323 145	1	Set screw st 8.8 M8 x 75 mm
46	100 331 013	2	Flat washer M8
47	100 315 012	5	Nut M8
48	121 100 161	2	Chain housing
49	121 100 175	1	Trunbuckle
50	100 331 096	1	Flat washer M8
51	121 134 244	1	Spring
52	121 100 174	1	Chain
53	100 401 011	2	Ball bearing # 6206 - 2RS1
54	121 100 380	1	Chain wheel
55	100 401 033	2	Ball bearing # 6203 - 2RS1
56	100 405 021	1	Key 5 x 5 x 20 mm
57	121 100 376	1	Entry shaft
Cpl:	121 100 160	1	Chain gear complete, incl. items 44 - 57
58	121 100 217	2	Flat washer \varnothing 60/7 x 2 mm
59	100 308 025	2	Set screw st 8.8 M6 x 25 mm
62	100 321 010	4	Torx screw M5 x 12 mm
63	121 000 686	4	Belt guard mounting plate
64	121 100 183	1	Outside belt guard
65	121 000 402	4	Belt guard mounting clip
66	121 100 203	1	V-belt pulley SPZ 200/1 groove
67	100 403 090	1	Raw edge moulded notch V-belt SPZ 950
68	100 308 018	2	Steel set screw M6 x 12 mm
69	100 331 004	8	Flat washer M6
70	121 100 193	1	Inside belt guard
71	100 332 002	2	Star washer M6
72	100 315 028	2	Nut M6
75	131 081 095	1	V-belt pulley SPZ 43/1 groove, bore \varnothing 19 mm. 50 Hz - 1400 rpm
77	100 322 000	1	Stop screw M6 x 6 mm
78	100 501 144	1	Motor 80 K4, 0.55 kW, B3, 3 x 400 V
	100 501 212	1	Motor 1750RPM, 0.55 kW, B3, 3 x 230 V, 60Hz
79	100 308 002	4	Set screw M8 x 25 mm
80	100 332 003	4	Star washer M8
81	100 331 005	4	Flat washer M8
82	100 308 018	4	Set screw st 8.8 M6 x 12 mm
84	121 100 200	1	Motor mounting plate
86	100 332 002	4	Star washer M6
87	100 315 028	4	Nut M6

SUC 100 & 150 E

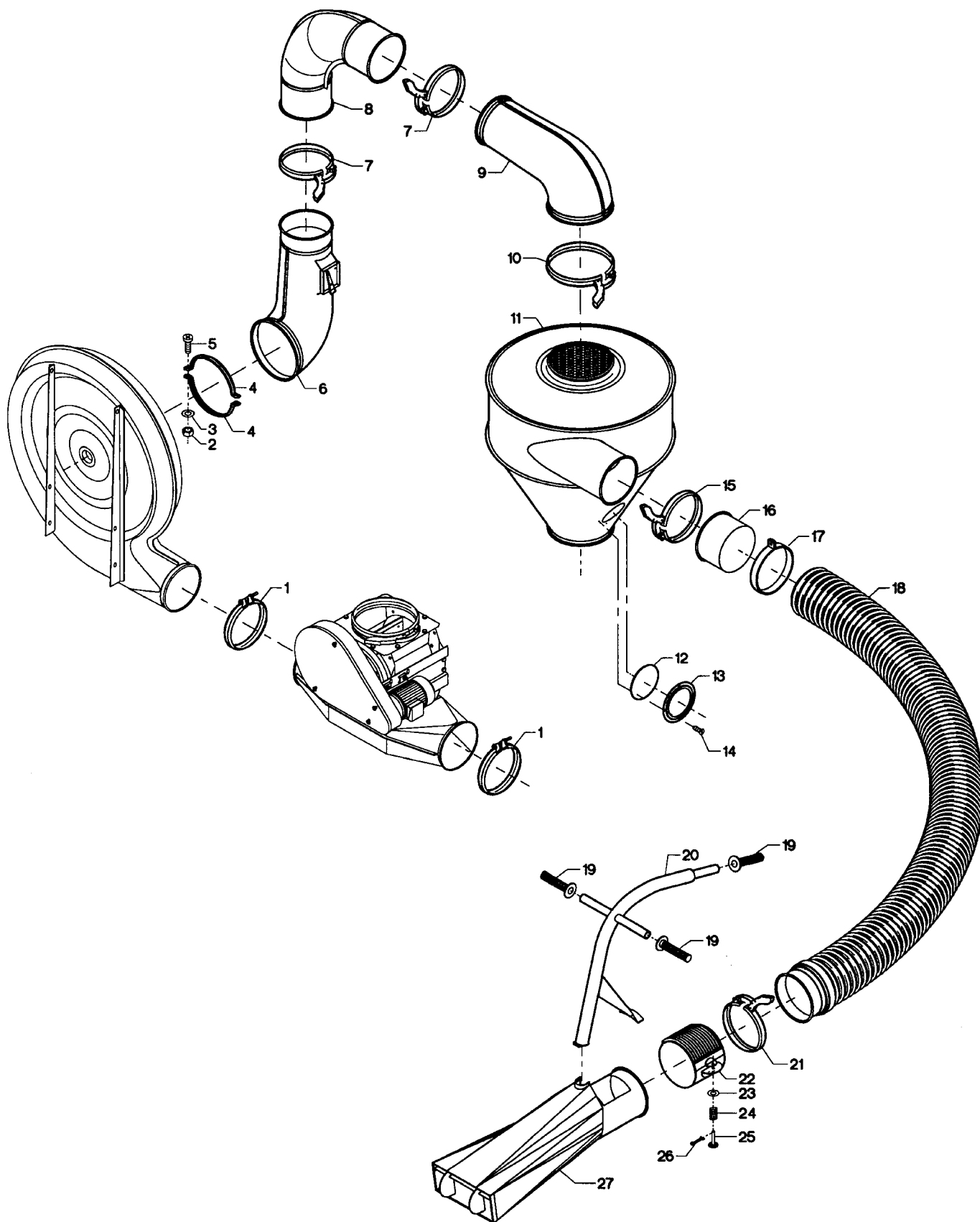

Fig.	Part no.	Pieces	Notes
1	122 001 078	2	Bolt clamp OK160, for spec. safety joint, Deltatone
2	100 315 028	2	Nut M6
3	100 332 002	2	Star washer M6
4	121 000 727	2	
5	100 321 018	2	Torx screw M6 x 30 mm
6	121 089 053	1	
7	122 000 800	2	Quick release clamp OKR160
8	121 089 107	1	Bend 90° OK160
9	121 140 175	1	Bend 90°, OK160 to OK200
10	122 050 150	1	Quick release clamp OK200, grey
12	121 000 090	1	Inspection window
13	121 000 089	1	Inspection window frame
14	100 323 011	4	Self-tapping screw # 8 x 5/16"
Cpl:	121 120 280	1	SC-cyclone complete, incl. items 11 - 14
15	122 000 824	1	Quick release clamp OK160, grey
16	121 000 775	2	
17	100 420 172	2	Clamp
Cpl:	121 000 645	1	Suction hose complete, incl. items 15 - 18
19	100 414 016	3	
20	121 130 246	1	
21	122 000 800	1	Quick release clamp OKR160
22	121 130 100	1	Air regulator
23	100 331 013	1	Flat washer M6
24	121 120 116	1	Spring
25	121 120 113	1	Push rod
26	100 333 000	1	Split pin ø2 x 15 mm
27	121 130 266	1	Suction head
Cpl:	121 130 247	1	Suction head complete, incl. items 19 - 27

